



OS-1 to OS-128

Sullair Oil-Water Separator
Removes Oil-Contaminated Compressor Condensate
Protects your compressed air system *and* the environment.

The Problem

Virtually all compressed air systems contain some water, dirt, rust or even degraded lubricating oil which all mix together to form unwanted compressed air condensate. This abrasive sludge collects in piping systems, filters, aftercoolers and dryers and must be efficiently removed before it brings your production process to an expensive standstill.

Why oil is a problem?

Oil can seriously effect the efficient operation of sewage purification by obstructing oxygen transfer to the bacteria essential for sludge digestion. Because of the serious effects oil can create, very low industrial discharge limits are permitted. Rigid legislation protects the environment against contamination.

Most users of compressed air systems are unaware of exactly how much condensate is produced by their system each year, and the effect it can have on the environment. For example: A 75 hp compressed air system can produce more than 16,000 gallons of oil-contaminated condensate a year and just one gallon of oil can cover 4 acres of water surface.

Recognizing that the safe removal of industrial wastewater is vitally important for our environment, Sullair offers the Sullair OS Oil-Water Separator. These separators, which can be installed on site, guarantee clean discharge water and ensure compliance with environmental laws.*

Special Features

- Single piece units – reduce overall footprint
- Rugged, corrosion resistant, polyethylene construction, includes ribbing for extra strength.
- Large centrifugal inlet chamber provides effective venting of compressed air, while two inlet ports and four inlet chamber positions simplify installation.
- Large, easily cleaned primary settlement chamber for the accumulation and removal of dirt particles
- Large main tank increases settlement time and reduces oil carryover to carbon filter stage.
- Large internal passages reduce risk of an internal blockage and simplify maintenance.

- Oil absorbing pre-filter(s) protect carbon stage from bulk contamination.
- Large carbon stage for increased contact time, improving water quality and extending carbon life.
- High specification carbon for improved service intervals.
- Adjustable oil outlet funnel for the efficient removal of separated oil.
- Sealed external oil container for easy disposal.
- Sample tap removes need to disconnect outlet piping when obtaining a test sample.

* The Sullair Oil-Water Separator will not separate Sullair Sullube compressor fluid. However, Sullube is environmentally friendly and biodegradable. Consult local authorities.



This product is manufactured to the highest quality standards in an ISO 9001 certified quality system.

How it works

Condensate from the system will enter the oil/water separator under pressure, and is allowed to expand in the specially designed centrifugal inlet chamber.

Liquid will drop out of the air stream as it impinges on the chamber walls of the vortex generator, draining without turbulence into the primary settlement chamber below.

Dirt particles suspended in the condensate will settle to the bottom of the primary settlement chamber and the accumulating condensate will then flow into the main settlement tank.

Entrained droplets of oil dispersed in the water will rise to the surface due to the lower specific gravity of the oil, eventually coalescing to form a thick layer on the surface.

An adjustable oil funnel allows the oil to be continuously skimmed off the surface. Drained oil is collected in the external oil container where it can be disposed of according to legal requirements.

Cleaner water taken from the bottom of the tank, flows into the carbon stage, through a pre-filter, into the top of the carbon bags.

Any entrained droplets of oil remaining are then removed by adsorption.

The cleaned water can now be safely discharged to the sewer through the outlet.

Selection Criteria

There are many factors which are important in the selection of Sullair OS Oil/Water Separator. Ambient conditions of the installation site is the most important.

Correct selection is critical for the operation of the Oil/Water Separator. Increased condensate flow through an Separator reduces settlement time in the main tank, increases oil carry-over to the carbon stage and reduces contact time with the carbon. The overall effect of incorrect sizing is poor outlet water quality, reduced carbon filter life and the potential for overflowing.

Capacities shown in this literature are shown for average climate conditions. In conditions other than those shown, use the Correction Factors provided. If additional sizing assistance is required, please contact Sullair or your local Sullair distributor.

Due to the wide range of lubricants used in modern compressors, it would be difficult to make specific recommendations on their individual performance of separation from condensate. Generally air compressor lubricants fall into one of the following classifications:

- Mineral
- Poly alpha olefins (PAO)
- Trimethylolpropane Ester (TMP)
- Pentaerythrityl Ester (PE)
- Diesters
- Triesters
- Polyoxyalkylene glycol (PAG)
- Automatic transmission fluid (ATF)

To simplify the selection, lubricants have been split into three classifications depending upon their ability to separate within the Oil/Water Separator.

Classification A:

- Turbine Oil,
- Additive Free Oil

Classification B:

- Mineral,
- Poly alpha olefins (PAO)
- Trimethylolpropane Ester (TMP)
- Pentaerythrityl Ester (PE)
- Sullair SRF 1/4000
- Sullair II/8000
- Sullair 24KT

Classification C:

- Diesters
- Triesters
- Polyoxyalkylene glycol (PAG)

Automatic transmission fluid (ATF) cannot be separated by the OS Oil/Water Separator.

Drain Type

The condensate should be removed from the compressed air system using a drainage method that does not cause emulsification of the condensate and is appropriate for the unit.

Usual methods include :

- Level Operated Electronic Drain
- Float Drain
- Timed Solenoid Drain*

Sullair recommends the use of Sullair SCD condensate drains. Manual and Thermodynamic Disc trap drains must not be used with the Oil/Water Separators.

*If the use of Timed Solenoid Drains is unavoidable, steps must be taken to reduce the air loss as this has an emulsifying effect on the condensate.

Refrigerated Dryers

A refrigerated dryer installed in a compressed air system can significantly increase the condensate produced. The oil/water separator must be sized appropriately to treat the extra condensate produced. Flow capacities on the facing page are shown both with and without a refrigerated dryer installed.

Important Note:

Additives blended into the lubricants to prevent bacterial growth, rusting, corrosion, and to promote emulsification, such as detergents etc., can have an impact on the separating process. Oil/Water Separators are unable to separate stable emulsions or oils that are miscible in water. Additionally, these units will not totally separate lubricants containing: Emulsifying agents; Glycol additives; or Polyglycol based coolants.

Sullair O/S Oil-Water Separator
Model Selection.

.....

No Refrigerated Dryer Installed in System

Classification A		Classification B		Classification C	
Turbine, Additive Free		Mineral, PAO, TMP, PE Sullair SRF 1/4000 and II/8000 Sullair 24KT		Diesters, Triesters, PAG	
Model	cfm	cfm	cfm	cfm	cfm
OS-1	87	73	60		
OS-16	138	117	95		
OS-20	212	181	147		
OS-33	441	375	305		
OS-49	822	750	610		
OS-94	1174	1000	812		
OS-128	2352	2000	1626		

With Refrigerated Dryer Installed in System

Classification A		Classification B		Classification C	
Turbine, Additive Free		Mineral, PAO, TMP, PE Sullair SRF 1/4000 and II/8000 Sullair 24KT		Diesters, Triesters, PAG	
Model	cfm	cfm	cfm	cfm	cfm
OS-1	65	55	45		
OS-16	103	88	71		
OS-20	159	135	110		
OS-33	330	281	228		
OS-49	660	561	456		
OS-94	879	749	607		
OS-128	1761	1497	1217		

System Conditions

Compressor Type: Rotary Screw or Vane * Ambient Temperature at Compressor Inlet: 70°F (21°C)
 Relative Humidity: 65% Compressor Discharge Temperature: 95°F (35°C)
 Refrigerated Dryer Dewpoint If Fitted: 36°F (2°C) System Pressure: 102 psig (7 barg)

* For use with reciprocating compressors, please contact Sullair.

For conditions other than those shown, e.g. higher ambient temperatures, please consult the Correction Factor tables below, or to properly size the Separator, contact Sullair.

Correction Factor for ambient temperature at the compressor inlet in degrees F.

Temperature °F	40°F	50°F	60°F	70°F	80°F	90°F	100°F	110°F	120°F
Temperature °C	4°C	10°C	16°C	21°C	27°C	32°C	38°C	43°C	49°C
Factor	2.82	1.96	1.39	1.00	0.73	0.54	0.40	0.31	0.22

Correction Factor for relative humidity of the ambient air at the compressor inlet.

RH	50%	55%	60%	65%	70%	75%	80%	85%	90%	95%	100%
Factor	1.30	1.18	1.08	1.00	0.93	0.87	0.81	0.76	0.72	0.68	0.65

Sullair Oil-Water Separator Specifications.

Model	OS-1	OS-16	OS-20	OS-33	OS-49	OS-94	OS-128
Inlet Connection I/D – in (mm)	3/4" (19)	3/4" (19)	3/4" (19)	1" (25)	1" (25)	1" (25)	1" (25)
Outlet Connection I/D – in (mm)	3/4" (19)	1" (25)	3/4" (19)	1" (25)	1" (25)	1" (25)	1" (25)
Settlement Tank Capacity – gal (l)	N/A	16 (60)	20 (75)	33 (125)	49 (185)	94 (355)	128 (485)
Maximum Pressure – psig (barg)	232 (16)	232 (16)	232 (16)	232 (16)	232 (16)	232 (16)	232 (16)
Minimum Temperature – °F (°C)	41 (5)	41 (5)	41 (5)	41 (5)	41 (5)	41 (5)	41 (5)
Maximum Temperature – °F (°C)	95 (35)	95 (35)	95 (35)	95 (35)	95 (35)	95 (35)	95 (35)
Material (Recyclable)	Polyethylene	Polyethylene	Polyethylene	Polyethylene	Polyethylene	Polyethylene	Polyethylene
Weight Empty – lbs (kg)	13 (6)	22 (10)	26 (12)	59 (27)	79 (36)	154 (70)	214 (97)
Weight Full – lbs (kg)	54 (24.5)	172.7 (78.5)	206 (93.5)	350 (159)	477 (217)	880 (400)	1210 (550)
Length "A" – in (mm)	12.4 (316)	14.0 (350)	14.0 (350)	26.0 (650)	26.0 (650)	34.0 (850)	34.0 (850)
Width "B" – in (mm)	10.6 (270)	17.0 (433)	18.0 (450)	20.0 (500)	26.0 (650)	28.0 (700)	39.0 (1000)
Height "C" – in (mm)	33.0 (842)	32.0 (810)	32.0 (810)	47.0 (1195)	47.0 (1195)	60.0 (1535)	60.0 (1535)

Sullair is committed to a program of continuous improvement. Features and specifications may change without notice. Consult your Sullair representative or authorized Sullair distributor.

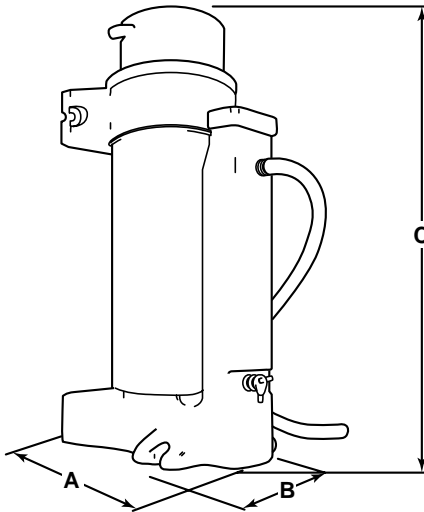

Model OS-1

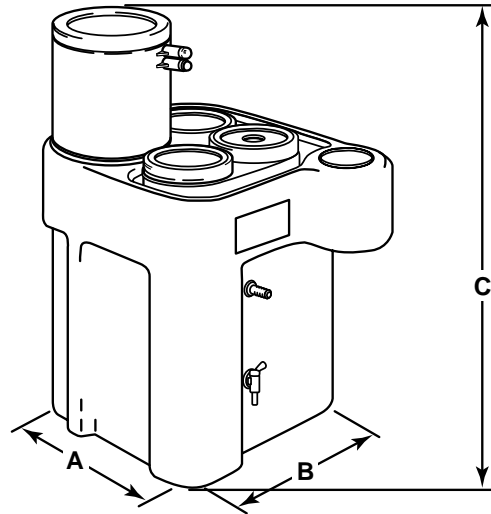

Models OS- to OS-128



This is one of several compressed air products that comprise the Sullair System. The System includes oil-free and lubricated air compressors, dryers, filters and related accessories designed to deliver peak performance and energy efficiency.



www.sullairsolutions.com

SULLAIR CORPORATION, 3700 East Michigan Boulevard, Michigan City, IN 46360 Telephone: 1-800-367-6737

CF02E Specifications subject to change without notice. © Copyright 2006 Sullair Corporation. All rights reserved. E/01/06/3



Printed on recycled paper